

## Vacuum Suction Pressure Casting Machine TCG-2001 Specifications

Power	AC200V(190 ~ 220V) 3ph 50/60Hz 6.5kVA
Size	750(W) × 750(D) × 1150(H)mm
Weight	300kg
Oscillator	4.8kw 38kHz ± 18
Range of thermometry	R-Sensor Below 1450°C
Sensor position	Selectable at time of purchase : bottom of crucible or in stopper
Max pressurization	0.2MPa
Max volume	K24 : 2.6kg Ag : 1.3kg
Mold sizes	Φ 76.3mm / Φ 89.1mm / Φ 101.6mm / Φ 114.3mm. Max height is 210H
Type of flask	Straight flask / Flask with a flange
Method of seal	Straight flask, Investment / Flask with a flange, Graphite. (Select before usage)
Casting program	20 patterns of setting can be programmed. (Settings for casting conditions, PID, thermal control, etc)
Casting methods	1.Vacuum and pressure 2.Vacuum, suction, and pressure 3.Vacuum, optional suction, and optional pressure (Semi-auto mode is available for 1 and 2)
Service power supply	1.5KVA can be used for vacuum pump, chiller, and so on
Other	Compressed air 5kg (Constant) Cooling water (2.0L / min) Vacuum pump (300L / min)

\* Design and specifications are subject to change without notice.

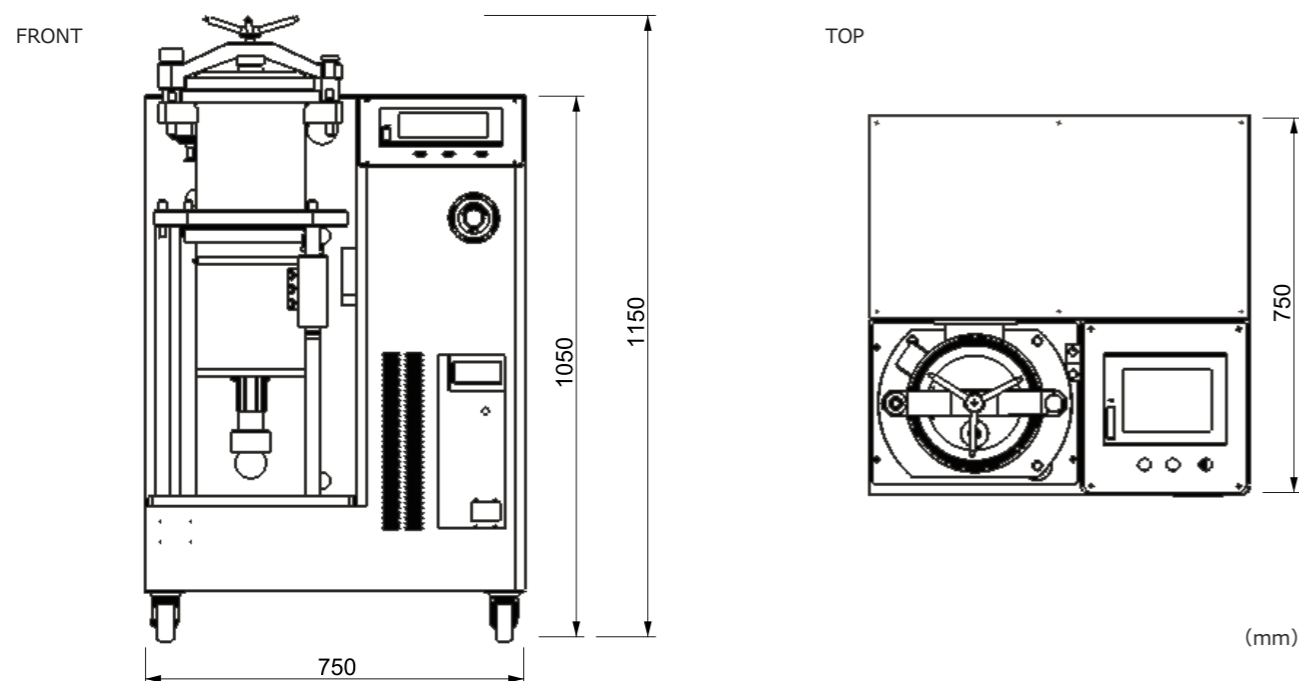

# Vacuum Suction Pressure Casting Machine

“Based on the feedback we got from experienced jewelry manufacturers, we have designed the ideal casting machine.”

真空吸引加圧鑄造機  
TCG-2001



 **TANABE**  
Unrivaled Accuracy

**TANABE KENDEN CO.,LTD.**

1-9-14 Fukasawa, Setagaya-ku, Tokyo  
158-0081 Japan  
Tel. +81-3-3704-3044  
<http://www.tanabekenden.co.jp/>

Please feel free to contact us with any questions or concerns. We are also able to provide demonstrations of our products.

 +81-3-3704-3044

 **TANABE**  
Unrivaled Accuracy  
<http://www.tanabekenden.co.jp/>

## TIP System™

With our exclusive TIP system, the gas pressure and vacuum can be thoroughly controlled separately in the upper and lower chambers. This allows for optimal conditions for pouring the alloy, thus reducing cracks and pinholes in the mold for the highest quality casting.



## Stainless steel chambers

Both the melting chamber and the molding chamber are made of stainless steel. Exceeding the strict Japanese safety standards, you can expect many years of usage.



## Multi-gas

You can select two types of gas for each of the two chambers. This can be done from the touch panel control. This is effective for reducing wear on the crucible and minimizing pinholes in the product.

## Accurate temperature control

We provide two options for the location of our temperature sensor: at the bottom of the crucible or inside the stopper.

Placing the sensor in the crucible allows for a higher accuracy of measurement, because there is less variation in the temperature with any amount or type of alloy, and lower possibility of breakage, as there is no need to move it when removing the stopper.

Placing the sensor in the stopper allows for those who have done so in the past with other machines to have consistent data.

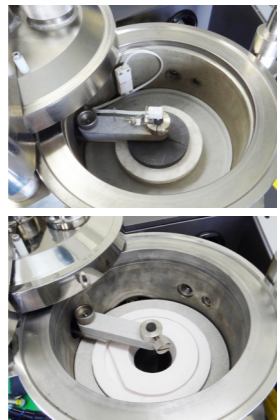

## Multi-seal

You can use either a straight flask or a flask with a flange without any need to make adjustments.



# What makes it better:

Highest casting quality in the world  
Maximum avoidance of pinholes and separation of alloys during casting through our oscillator and unique TIP system

Flexible, efficient operation system  
Select either automated, semi-automated, or manual mode to perform casting at a high level, whether you are new to casting or an experienced craftsman

Equipped with various reminders  
These reduce the possibility of operator error ruining your products or damaging the equipment



## Touch panel control

Equipped with a user-friendly touch panel for easily recalling previously done work and original programs.



## Various casting modes, programmable memory

Casting modes: Automated, semi-automated, and manual casting can all be handled.

Casting programs: Up to 20 programs can be set and stored.

## Job logs

There is a job-log that records the room temperature, chamber temperature, casting conditions, date, and time. By analyzing this, you can achieve better production control and casting quality.

## Multiple alarms

Equipped with multiple alarms to thoroughly check every step in the casting process, these stop the casting program when a problem is detected, avoiding accidents and damage to the products and the machine. The touch panel will alert you to what is wrong.



Sensors are checking the following parts or conditions: the stopper (the up-and-down movement, to avoid leakage of the melted alloy), the vacuum degree, the suction conditions, the melting, the up-and-down movement of the molding chamber, and the pressurization of the melting chamber and molding chamber.

## Tanabe exclusive high-spec oscillator

### Frequency:

The oscillator uses a frequency appropriate to the alloys, allowing for melting to be done quickly with minimal electricity usage.

Also, as a lower frequency is used, there is less wear on the crucible.

### Auto matching:

The oscillator automatically adjusts its output, so even if there is wear on the crucible, ideal melting conditions are maintained.

### Alloy mixing function:

Using our original mixing system, separation of the alloys is greatly reduced during the entire casting process.

### Maximum temperature of 1450°C :

Capable of even melting white gold.

